

Electret Microphone 2-Wire Connections

Conventional 3-wire connection

Tibbetts Industries 151, 251, and 351 series miniature microphones are designed for 3-wire connection in low voltage applications, typically operating with a supply voltage of 1.3 volts. This configuration uses one wire each to connect the microphone signal output, supply, and ground (or common) terminals to the outside circuit. The commonly used color scheme for cabled microphone assemblies is red for supply, white for signal, and black for ground.

A low-pass filter consisting of a capacitor and a resistor can be used on the supply line in the connecting circuit to make the microphone pre-amplifier less susceptible to power supply disturbances. Figures 1 and 2 below show the microphone and a 3-wire connection with power supply filtering. The resistor R1 in Figure 2 should be chosen such that the voltage drop across R1 does not appreciably reduce the operating voltage of the microphone pre-amplifier circuit (i.e. 1k Ω -2k Ω).

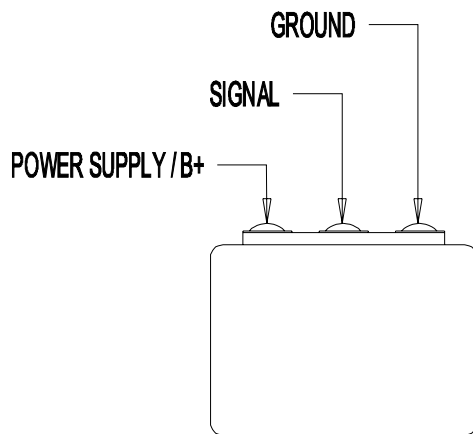

Figure 1. Microphone input/output terminals

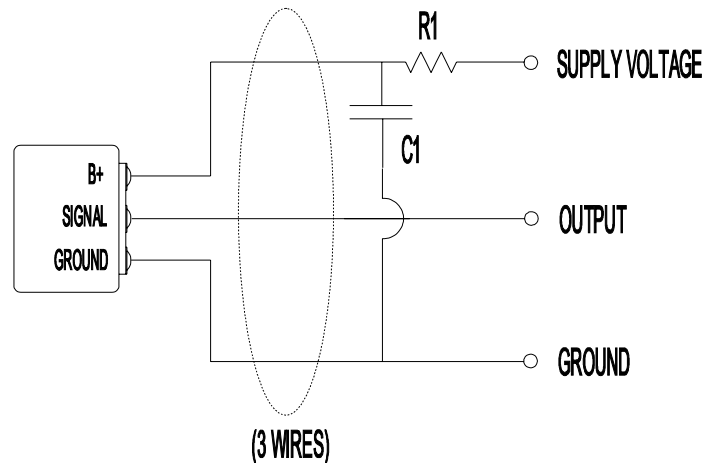

Figure 2. Microphone 3-wire connection

Modified wiring using 2-wire connection

These microphones may also be wired for operation using only 2 wires in several different configurations, some of which will be described below. Altering the standard connection to the microphone changes the operating characteristics of the microphone pre-amplifier, and thus alters the performance of the microphone. For each of the configurations described below, an external resistor is needed. The power supply filtering mentioned above may also be included.

The value chosen for the additional resistors in each of the circuits below depends heavily on the supply voltage used to power the microphone. In order to reduce the sensitivity of the microphone to acoustic levels that may overload the output and to maintain the correct biasing of the circuit, resistance values should be chosen to bias the output signal level at roughly half the supply voltage.

In each of the descriptions of 2-wire connected microphones given below, the performance changes are relative to the standard 3-wire configuration shown above.

2-wire option A

- Similar drain current ($\sim 20\mu\text{amps}$)
- Lower sensitivity
- R2 value $10\text{k}\Omega - 250\text{k}\Omega$ (w/ increasing B+)
- Higher power supply feedthrough
- Characteristics approach 3-wire config. w/ increasing R2

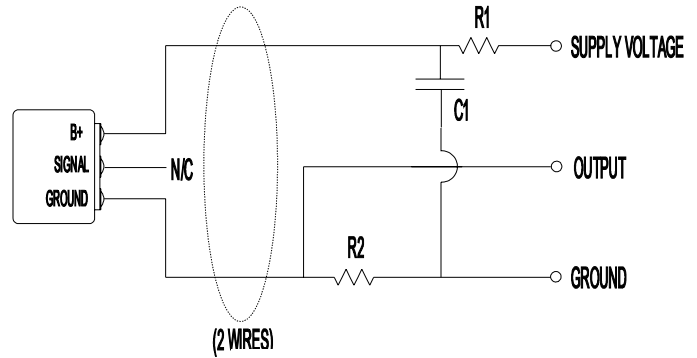

Figure 3. 2-wire option A

R2	Power Supply	1kHz sensitivity change
50k Ω	+5V	-3dB

Phantom powered 2-wire connections

The configurations described above use a separate line for the power supply voltage, isolating it from the other terminals. These microphones can also be powered by "phantom power," which is simply supply voltage that reaches the microphone through a signal line. In the following configurations, the microphone pre-amplifier is connected to the power supply through the same line the output signal is sent through. The microphone output signal for these 2-wire connections is reversed in phase compared to the standard 3-wire connection.

2-wire option B

- Similar drain current ($\sim 20\mu\text{amps}$)
- Phantom powered
- Higher sensitivity
- Higher Signal-to-Noise Ratio
- R3 value $10\text{k}\Omega - 250\text{k}\Omega$ (w/ increasing B+)
- Higher output impedance
- Higher power supply feedthrough

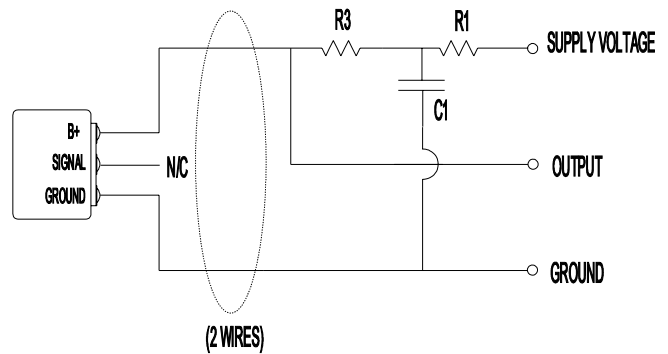

Figure 4. 2-wire option B

R3	Power Supply	1kHz sensitivity Change
100k Ω	+5V	+6dB

2-wire option C

- Higher drain current ($\sim 400\mu\text{amps}$)
- Phantom powered
- Higher sensitivity
- R4 value $1\text{k}\Omega - 10\text{k}\Omega$ (w/ increasing B+)
- Lower output impedance
- Better cable drive

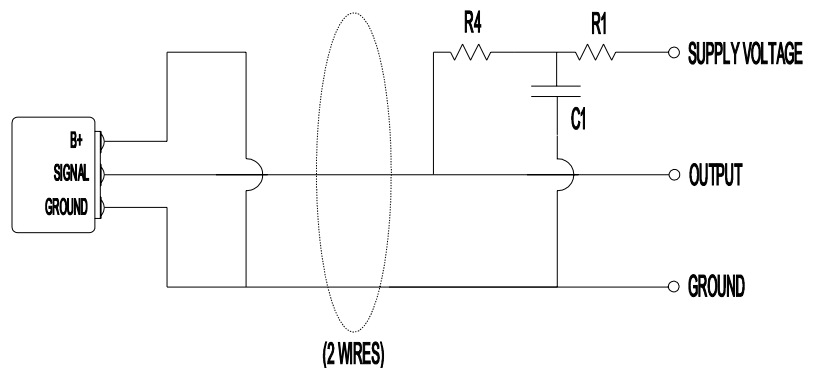

Figure 5. 2-wire option C

R4	Power Supply	1kHz sensitivity Change
5k Ω	+5V	+6dB